

| PARTS LIST | | | | | | |
|-------------|-----|------------|--|-----------|----------|---------|
| ITEM | QTY | PART NO. | PART DESCRIPTION | LENGTH | UNIT WT. | NET WT. |
| 1 | 1 | X-SOFTP18 | 18" STANDOFF PIPE-TO-PIPE WELDMENT | 18 in | 18.91 | 18.91 |
| 2 | 2 | X-SO12-CLS | V-CLAMP FOR 0.5" HARDWARE | 7 9/16 in | 3.33 | 6.66 |
| 3 | 8 | G1206 | 1/2" x 6" HDG HEX BOLT GR5 FULL THREAD | 6 in | 0.38 | 3.05 |
| 4 | 8 | G12FW | 1/2" HDG USS FLATWASHER | 3/32 in | 0.03 | 0.27 |
| 5 | 8 | G12LW | 1/2" HDG LOCKWASHER | 1/8 in | 0.01 | 0.11 |
| 6 | 8 | G12NUT | 1/2" HDG HEAVY 2H HEX NUT | 7/8 in | 0.07 | 0.57 |
| TOTAL WT. # | | | | | | 29.58 |

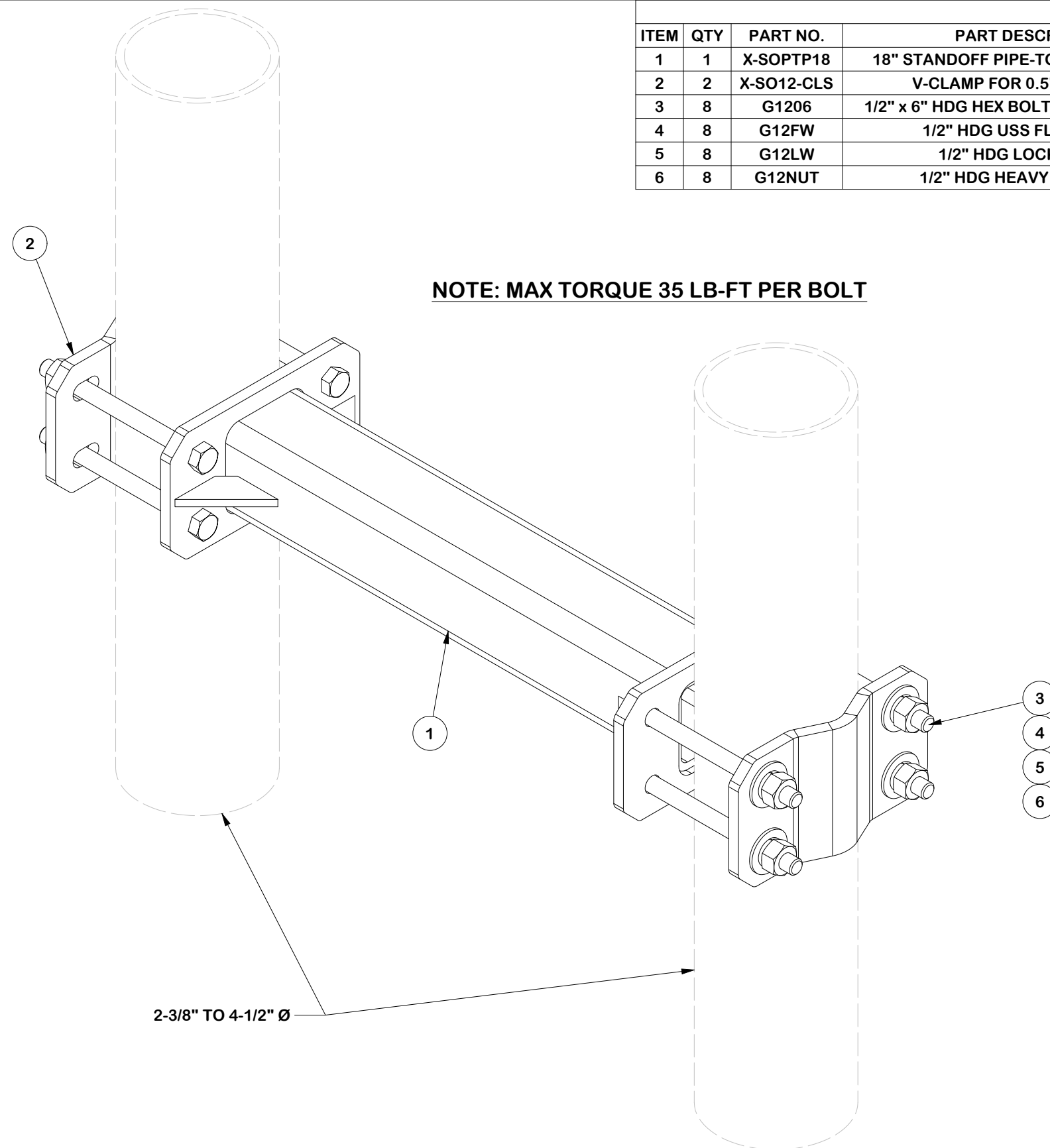

NOTE: MAX TORQUE 35 LB-FT PER BOLT

FINISH:
HOT DIP GALVANIZED.

| REV | DESCRIPTION OF REVISIONS | CPD | BY | DATE |
|-------------------------|--|-----|-----|----------|
| A | REVISED X-SOFTP18 AND CHANGED TO 1/2" HW | NCS | SDR | 8/4/2025 |
| REVISION HISTORY | | | | |

TOLERANCE NOTES

TOLERANCES ON DIMENSIONS, UNLESS OTHERWISE NOTED ARE:
 SAWED, SHEARED AND GAS CUT EDGES ($\pm 0.030"$)
 DRILLED AND GAS CUT HOLES ($\pm 0.030"$) - NO CONING OF HOLES
 LASER CUT EDGES AND HOLES ($\pm 0.010"$) - NO CONING OF HOLES
 BENDS AND ANGLES ARE $\pm 1/2$ DEGREE
 ALL OTHER MACHINING ($\pm 0.030"$)
 ALL OTHER ASSEMBLY ($\pm 0.060"$)

PROPRIETARY NOTE:
THE DATA AND TECHNIQUES CONTAINED IN THIS DRAWING ARE PROPRIETARY INFORMATION OF VALMONT INDUSTRIES AND CONSIDERED A TRADE SECRET. ANY USE OR DISCLOSURE WITHOUT THE CONSENT OF VALMONT INDUSTRIES IS STRICTLY PROHIBITED.

| DESCRIPTION | | | |
|---|---------------|---------------|---------------|
| 18" UNIVERSAL STANDOFF PIPE-TO-PIPE KIT | | | |
| CPD NO. | DRAWN BY | ENG. APPROVAL | |
| NCS | SDR 8/20/2024 | 9/18/2025 | |
| CLASS | SUB | DRAWING USAGE | CHECKED BY |
| 87 | 02 | CUSTOMER | JET 9/18/2025 |

| | |
|-----------------------|--|
| A valmont COMPANY | Engineering Support Team: 1-888-753-7446 |
| | PART NO. SOFTP18-U DWG. NO. SOFTP18-U |